

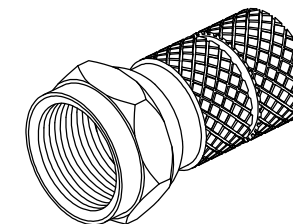

ROHS COMPLIANCE

DATE	DESCRIPTION	REV
13.11.25	NEW RELEASE	A

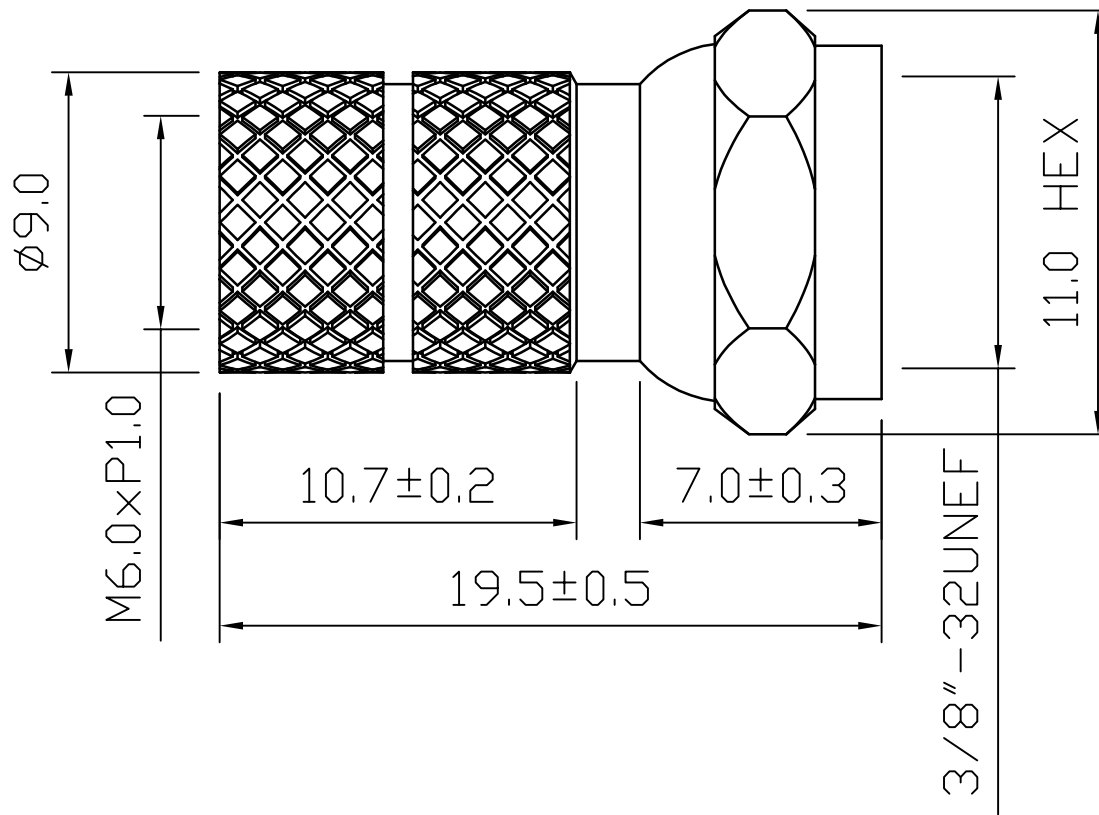

DO NOT SCALE DRAWING

UNLESS OTHERWISE SPECIFIED 1. REMOVE ALL BURRS. 2. BREAK ALL CONNERS & EDGES CO.15 MAX. 3. CHAMFER 1ST & LAST THREADS 45°. 4. DIAMETERS ON COMMON CENTERS. TO BE CONCENTRIC WITHIN 0.01 T.I.R. 5. ALL DIMENSIONS ARE AFTER PLATING.	MAJOR DIMENSIONS		APPROVED BY	DRAWING NO
	UNLESS OTHERWISE NOTED TOLERANCES		CHECKED BY	F-009-1N-B
	0.5-6=±0.2		DRAWING BY	TITLE
	6-30=±0.4		<i>Sheng</i>	F MALE TWIST ON FOR RG/59U/4C
30-120=±0.6		DATE	2013/11/25	REV. A
ANGLES=±5°		 WEIJE ELECTRONICS CO., LTD		

NO	Description	Q'ty	Material	Finish	Part Number
2	BODY	1	BRASS	NICKEL	
1	SHELL	1	BRASS	NICKEL	