

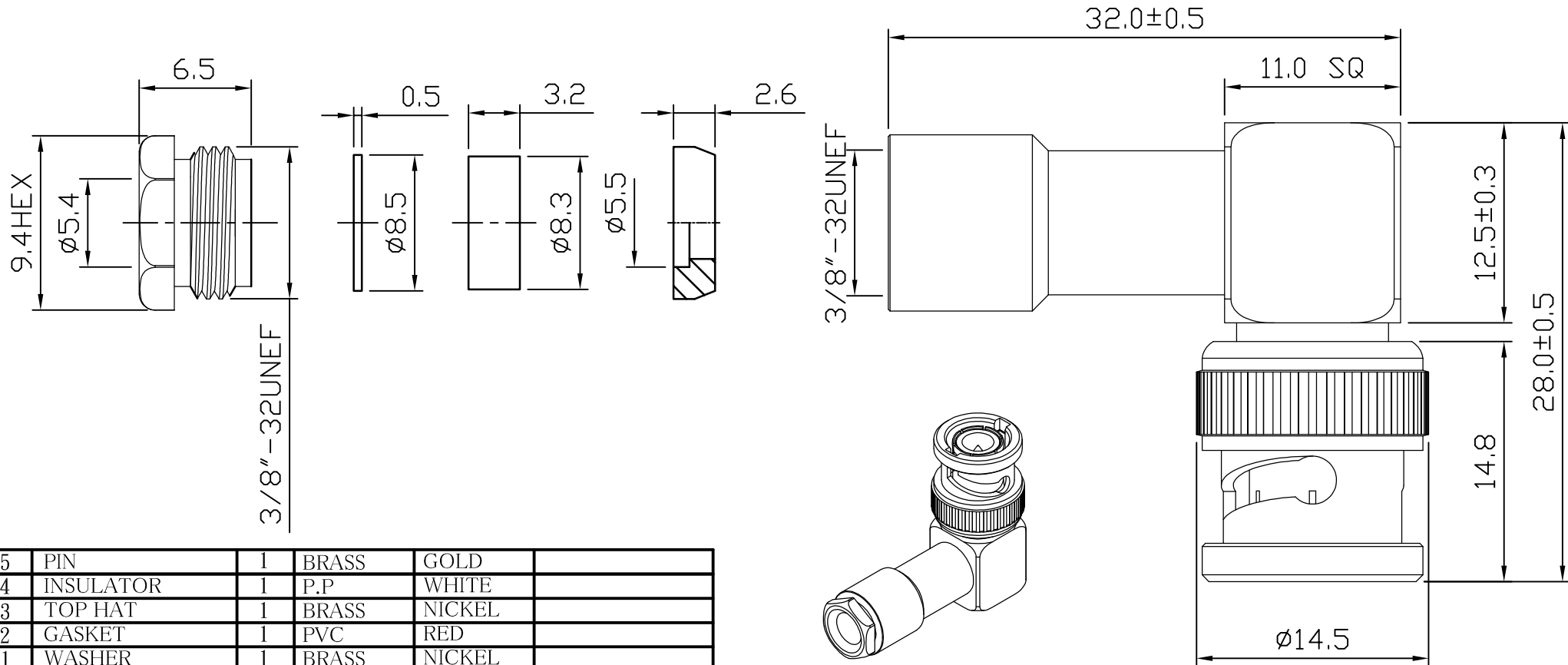

ROHS COMPLIANCE

DATE	DESCRIPTION	REV
14.01.10	NEW RELEASE	A



15	PIN	1	BRASS	GOLD	
14	INSULATOR	1	P.P	WHITE	
13	TOP HAT	1	BRASS	NICKEL	
12	GASKET	1	PVC	RED	
11	WASHER	1	BRASS	NICKEL	
10	SCREW	1	ZINC	NICKEL	
9	BODY	1	BRASS	NICKEL	
8	PIN	1	BRASS	GOLD	
7	INSULATOR	1	POM	WHITE	
6	GASKET	1	PVC	RED	
5	WASHER	1	STEEL	NICKEL	
4	SPRING	1	SK-5	NICKEL	
3	WASHER	1	STEEL	NICKEL	
2	BODY	1	BRASS	NICKEL	
1	SHELL	1	ZINC	NICKEL	
NO	Description	Q'ty	Material	Finish	Part Number

UNLESS OTHERWISE SPECIFIED 1. REMOVE ALL BURRS. 2. BREAK ALL CONNERS & EDGES CO.15 MAX. 3. CHAMFER 1ST & LAST THREADS 45°. 4. DIAMETERS ON COMMON CENTERS. TO BE CONCENTRIC WITHIN 0.01 T. I. R. 5. ALL DIMENSIONS ARE AFTER PLATING.	MAJOR DIMENSIONS		APPROVED BY	DRAWING NO	
	UNLESS OTHERWISE NOTED TOLERANCES		CHECKED BY	B-010-2DGN-A	
	0.5-6=±0.2		DRAWING BY	TITLE	
	6-30=±0.4		Sheng	BNC M R/A CLAMP FOR RG58/U	
30-120=±0.6		DATE	REV.		
ANGLES=±5°		2014/01/10	A		
SCALE	4/1	UNIT	WEIJE ELECTROICS CO., LTD		
	MM				

DO NOT SCALE DRAWING